

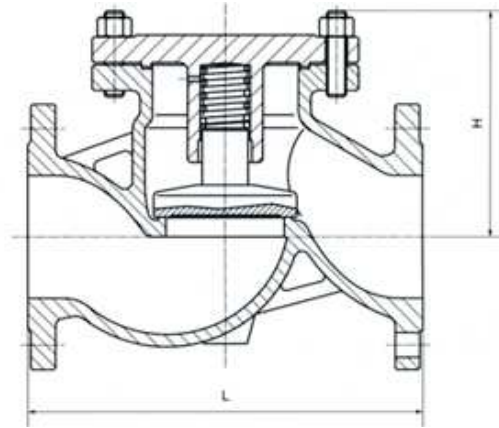

DIN F1 LIFT CHECK VALVE



Features:

DIN F1 LIFT CHECK VALVE

Technical specification

Structural Formation	BB-BG-OS & Y
Driving Manner	Hand-Operated
	Electric-Actuated
Design Standard	DIN3356
Face to Face	DIN3202
Flange Ends	DIN2543-2547
Test & Inspection	DIN3230

Notes: The size of serial, valve connecting flange can be design according to customers requirment.

Products performance specification

Nominal Pressure (Mpa)	Shell Test(Mpa)	Sealing Test(Mpa)	Suitable Temp(oC)	Suitable Medium
1.6	2.4	1.76	-110~600 oC	Water Oil & Gas
2.5	3.75	2.75		
4.0	6.0	4.4		
6.4	9.6	7.04		



Main Dimensions

unit:mm

Pressure (Mpa)	PN 1.6 Mpa										
	Size	50	65	80	100	125	150	200	250	300	350
L	230	290	310	350	400	480	600	730	850	980	1100
H	305	354	402	437	496	541	699	815	914	1189	1350
Weight(kg)	10	20	30	39	50	70	161	251	395	500	618

Pressure (Mpa)	PN 2.5 Mpa										
	Size	50	65	80	100	125	150	200	250	300	350
L	230	290	310	350	400	480	600	730	850	980	1100
H	325	363	415	453	505	556	744	864	948	1269	1450
Weight(kg)	12	22	33	44	55	78	180	270	410	520	650

Pressure (Mpa)	PN 4.0 Mpa										
	Size	50	65	80	100	125	150	200	250	300	350
L	230	290	310	350	400	480	600	730	850	980	1100
H	325	370	430	480	532	589	783	888	965	1285	1512
Weight(kg)	13	23	34	46	60	85	190	280	430	550	680